

PLATFORM LIFTER

AB-FLB-PLT5

ATOMBOTIX



Advanced Safety Protection



Equipped with front laser obstacle avoidance, collision detection bumpers, and an emergency stop button for enhanced operational safety

Efficient Power Management



Supports multi-level battery threshold control, customizable minimum charging levels, and idle-time charging management

Cargo Lifting & Handling



Supports lifting and transporting operations for cargo up to 50 kg payload capacity

Smart Connectivity & Control



Supports Wi-Fi communication with seamless roaming, and offers automatic, manual, and remote-control operation modes

Precise Positioning & Navigation



Utilizes QR-code and SLAM navigation technologies for accurate positioning and flexible route planning

Flexible Motion Control



Dual-wheel differential drive supports forward, backward, rotation, and multiple movement modes

Model	AB-FLB-PLT5
Feature	
Drive Mode	Differential drive of two wheels
Dimensions	678 × 450 × 435 mm
Rotation Diameter	678 mm
Self-weight	70 kg
Rated Load	50 kg
Chassis Ground Clearance	25 mm
Lifting Panel Size	606×405 mm
Lifting Height	400 mm

Motion	
Rated Operating Speed (Rated Load/No Load)	3.5 m/s; 4 m/s
Acceleration (Rated Load/No Load)	1.2 m/s ² ; 2 m/s ²
Rotation Speed (Full Load/No Load)	300°/s; 350°/s
Battery	
Battery Type	Lithium iron phosphate
Capacity/Rated Voltage	10 Ah/48V
Charge-Discharge Cycle Times	1,500 times
Rated Working Condition Endurance Time	4-6 h
Charging Time After Complete Discharge	≤1.5 h
Communication Protocol	CAN/RS485
Other Parameters	
Human-Computer Interaction Mode	/
Navigation Mode	Laser SLAM or 2D code
Front Laser Obstacle Avoidance (Quantity/Installation Height)	1 piece/185 mm
Opening Angle	180°
3D Vision Obstacle Avoidance	/
Rear Ultrasonic	/
Emergency Stop Buttons	2 pieces (front and rear each 1)
Contact Protection	Piezoelectric edge switch
Acoustic-Optic Alarm	Standard
Chassis Damping Mode	Floating chassis
Climbing Capacity	≤5%/3°
Step Capacity	≤3 mm
Gutter Crossing Capacity	≤3 mm
Signal	Supports dual-band Wi-Fi (2.4 GHz and 5 GHz), with wireless signal strength ≥ -70 dBm
Humidity	Relative humidity 10%–90% without condensation
Temperature	Working area: -10°C–40°C Charging area: 0°C–40°C

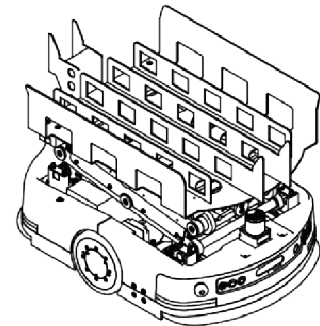
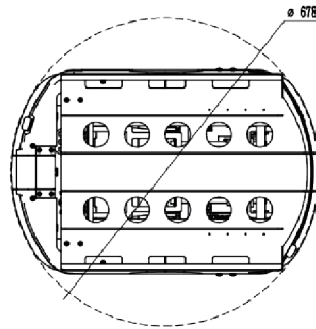
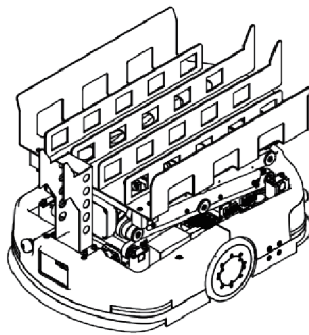
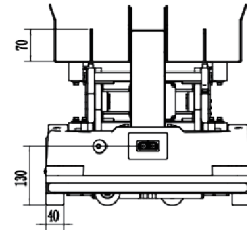
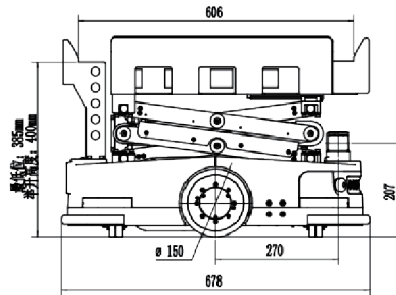
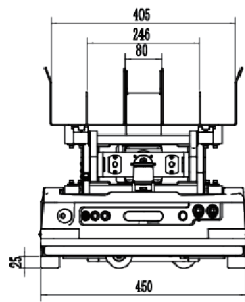

AGV Charging Station Docking Illustration:

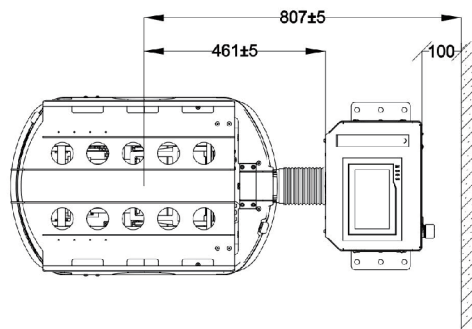

www.atombotix.com
contact@atombotix.com

